



# ANZEIGER FÜR WÄRMETECHNIK INDICATORS FOR HEATING TECHNOLOGIES

SGL, DA  
Stahl, Edelstahl  
Steel, Stainless Steel

# SGL / DA

SGL: Schauglas  
 Inspection glass  
 HT - Temperatur bis +200°C / temperature until +200°C

SGL	Anschluss connection	Form design	Werkstoff material	Ventiltyp valve type	Seite page
SGL	Werkstoffe / materials				14.2
SGL PS25 / PS40 PS63	Anschweißende butt welding ends		St	SGL AE	14.3
			NIRO	SGL AE NIRO	14.4
	Schraubende screwed ends		St	SGL SE	14.5
			NIRO	SGL SE NIRO	14.6

DA: Durchflussanzeiger  
 Flow indicators  
 HT - Temperatur bis +200°C / temperature until +200°C

DA	Anschluss connection	Form design	Werkstoff material	Ventiltyp valve type	Seite page
DA	Werkstoffe / materials				14.7
DA PS25 / PS40 / PS63	Flanschanschluss flanged ends		St	DA FL	14.8
Informationen	Vergleich europäische/amerikanische Werkstoffe / Comparison American vs. European material numbers				14.9
	Codierung Anschlüsse Klein- und Serviceventile / Connection codes for service valves and small valves				14.10
	DIN-FL Vorschweißflansche - DIN / Welding neck flanges - DIN				14.11/14.12
	EN-FL Vorschweißflansche - EN / Welding neck flanges - EN				14.13/14.14
	ANSI-FL Vorschweißflansche - glatt / Welding neck flanges - raised face				14.15
	AWP-FL Vorschweißflansche - AWP / Welding neck flanges - AWP				14.16
Rechtliche Hinweise / Legal Note					14.17

St = Stahl / steel NIRO = nicht rostender Edelstahl / stainless steel

# SGL Werkstoffe / materials

Benennung und Materialien / naming and materials

SGL HT - Schauglas / inspection glass

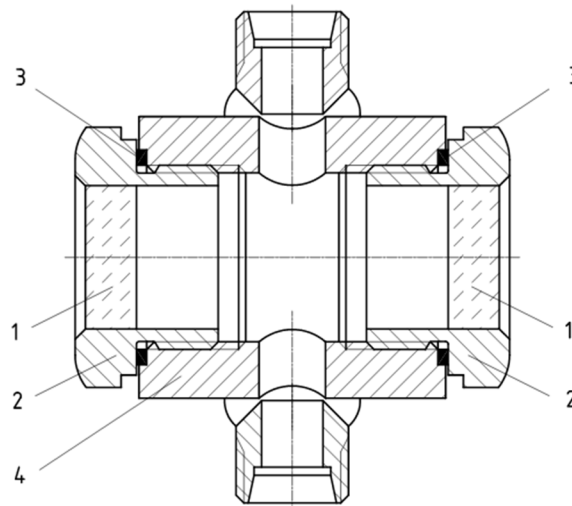

	Einzelteil / part:	Werkstoff Stahlventile material steel valves	Werkstoff Edelstahlventile material stainless steel valves
1	Glas / glass	Kalknatronglas / soda-lime glass	Kalknatronglas / soda-lime glass
2	Schraubstück / threaded nipple	S235JR 1.0038	X5CrNi18-10 1.4301
3	Flachdichtung / flat gasket	AL	AL
4	Gehäuse / body	S355J2 1.0577	X5CrNi18-10 1.4301

# SGL Stahl / steel

Schauglas  
Inspection glass

für natürliche Gase und Flüssigkeiten (z.B. NH<sub>3</sub>, CO<sub>2</sub>) und nicht korrosive Medien nach EN 378-1  
for natural gases and liquids (e.g. NH<sub>3</sub>, CO<sub>2</sub>) as well as non-corrosive media according to EN 378-1

## SGL AE HT

**AE** - Anschweißenden / butt welding ends

**HT** – Temperatur bis +200°C / temperature until +200°C

Druck- / Temperatureinsatzgrenzen:

Pressure - / temperature limits of application:

**PS:** max. zulässiger Betriebsdruck in bar ü / max. allowable working pressure in bar gauge

**TS:** den zulässigen Betriebsüberdrücken (PS) zugeordnete zulässige Betriebstemperatur in °C / max. allowable working temperature in °C, associated with PS

DN / INCH	PN	-10	+50	+200	TS [°C]
<b>DN 10...100</b> <b>3/8"...4"</b>	PN25	25	25	25	PS [bar]
	PN40	40	40	40	PS [bar]
	PN63	63	63	63	PS [bar]

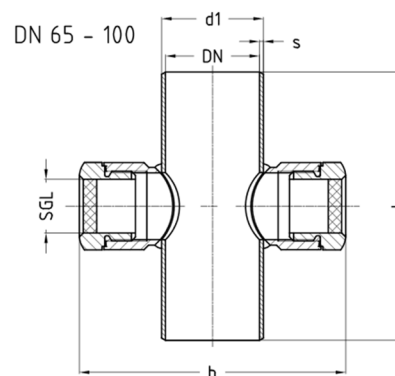
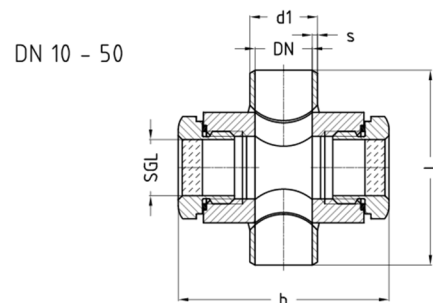

Abmessungen / dimensions in mm:

Nominal size:		Anschweißenden gemäß: / butt welding ends acc. to:								
		ISO Reihe 1 ISO series 1			ANSI Sched 40					
DN	INCH	d1	s <sup>1)</sup>	s <sup>2)</sup>	d1	s	l	h	Ø SGL*	
10	3/8"	17,2	1,8	1,8	17,1	2,3	96	85	28	
15	1/2"	21,3	2,0	2,0	21,3	2,8	96	85	28	
20	3/4"	26,9	2,3	2,6	26,7	2,9	100	85	28	
25	1"	33,7	2,6	2,6	33,4	3,4	97	105	28	
32	1 1/4"	42,4	2,6	2,9	42,2	3,6	97	105	28	
40	1 1/2"	48,3	2,6	2,9	48,3	3,7	122	162	40	
50	2"	60,3	2,9	2,9	60,3	3,9	122	162	40	
65	2 1/2"	76,1	2,9	3,2	73,0	5,2	200	199	40	
80	3"	88,9	3,2	3,6	88,9	5,5	200	212	40	
100	4"	114,3	3,6	4,0	114,3	6,0	200	237	40	

Ø SGL\* = Durchmesser Schauglas / sight glass diameter 1) PN25 / PN40 2) PN63

GEA AWP GmbH

Armaturenstraße 2, 17291 Prenzlau, Germany  
Tel: +49 39848559-0 Fax: +49 39848559-18  
info.awpvalves@gea.com, www.awpvalves.com

14.3

# SGL Edelstahl / stainless steel

Schauglas  
Inspection glass

für natürliche Gase und Flüssigkeiten (z.B. NH<sub>3</sub>, CO<sub>2</sub>) und nicht korrosive Medien nach EN 378-1  
for natural gases and liquids (e.g. NH<sub>3</sub>, CO<sub>2</sub>) as well as non-corrosive media according to EN 378-1

## SGL AE NIRO HT

AE - Anschweißenden / butt welding ends

HT – Temperatur bis +200°C / temperature until +200°C

Druck- / Temperatureinsatzgrenzen:

Pressure - / temperature limits of application:

PS: max. zulässiger Betriebsdruck in bar ü / max. allowable working pressure in bar gauge

TS: den zulässigen Betriebsüberdrücken (PS) zugeordnete zulässige Betriebstemperatur in °C / max. allowable working temperature in °C, associated with PS

DN / INCH	PN	-10	+50	+200	TS [°C]
DN 10...100 3/8"...4"	PN25	25	25	25	PS [bar]
	PN40	40	40	40	PS [bar]
	PN63	63	63	63	PS [bar]

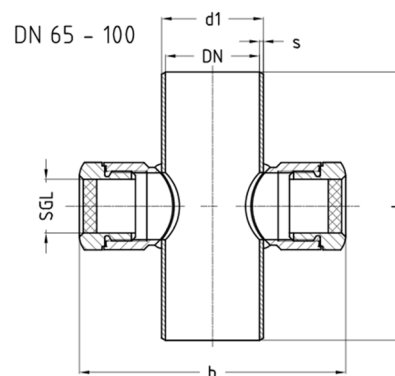
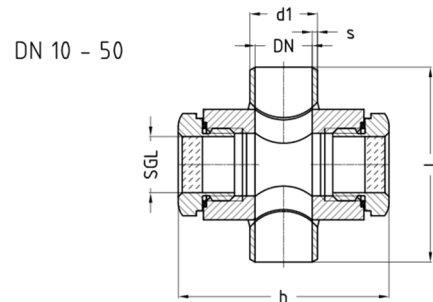

Abmessungen / dimensions in mm:

Nominal size:		Anschweißenden gemäß: / butt welding ends acc. to:								
		ISO Reihe 1 ISO series 1			ANSI Sched 40					
DN	INCH	d1	s <sup>1)</sup>	s <sup>2)</sup>	d1	s	l	h	Ø SGL*	
10	3/8"	17,2	1,8	1,8	17,1	2,3	96	85	28	
15	1/2"	21,3	2,0	2,0	21,3	2,8	96	85	28	
20	3/4"	26,9	2,3	2,6	26,7	2,9	100	85	28	
25	1"	33,7	2,6	2,6	33,4	3,4	97	105	28	
32	1 1/4"	42,4	2,6	2,9	42,2	3,6	97	105	28	
40	1 1/2"	48,3	2,6	2,9	48,3	3,7	122	162	40	
50	2"	60,3	2,9	2,9	60,3	3,9	122	162	40	
65	2 1/2"	76,1	2,9	3,2	73,0	5,2	200	199	40	
80	3"	88,9	3,2	3,6	88,9	5,5	200	212	40	
100	4"	114,3	3,6	4,0	114,3	6,0	200	237	40	

Ø SGL\* = Durchmesser Schauglas / sight glass diameter 1) PN25 / PN40 2) PN63

GEA AWP GmbH

Armaturenstraße 2, 17291 Prenzlau, Germany  
Tel: +49 39848559-0 Fax: +49 39848559-18  
info.awpvalves@gea.com, www.awpvalves.com

# SGL Stahl / steel

## Schauglas Inspection glass

für natürliche Gase und Flüssigkeiten (z.B. NH<sub>3</sub>, CO<sub>2</sub>) und nicht korrosive Medien nach EN 378-1  
for natural gases and liquids (e.g. NH<sub>3</sub>, CO<sub>2</sub>) as well as non-corrosive media according to EN 378-1

### SGL SE HT

**SE** - Schraubenden / screwed ends

**HT** – Temperatur bis +200°C / temperature until +200°C

Druck- / Temperatureinsatzgrenzen:

Pressure- / temperature limits of application:

**PS:** max. zulässiger Betriebsdruck in bar ü / max. allowable working pressure in bar gauge

**TS:** den zulässigen Betriebsüberdrücken (PS) zugeordnete zulässige Betriebstemperatur in °C / max. allowable working temperature in °C, associated with PS

DN / INCH	PN	-10	+50	+200	TS [°C]
<b>DN 6...20</b> <b>1/8"....3/4"</b>	PN25	25	25	25	PS [bar]
	PN40	40	40	40	PS [bar]
	PN63	63	63	63	PS [bar]

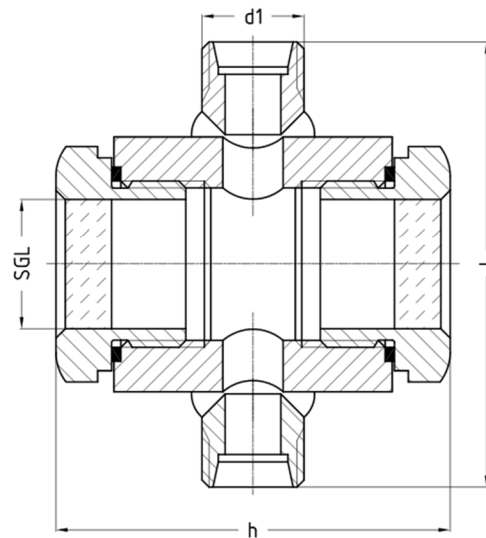

Abmessungen / dimensions in mm:

Nominal size:	Schraubenden gemäß: screwed ends acc. to:			
DN	d1*	l	h	Ø SGL*
6	G3/8"	96	85	28
8	G1/2"	105	85	28
8	G1/4"-i	105	85	28
8	M16x1,5 L RA10	96	85	28
8	M18x1,5 S RA10	96	85	28
8	M18x1,5 L RA 12	96	85	28
10	M26x1,5	96	85	28
15	G1"	126	85	28
20	M36x2,0 L RA28	126	85	28
20	G1 1/4"	126	85	28

d1\* = andere Gewindeanschlüsse siehe technischer Anhang / other thread connections see technical appendix

Ø SGL\* = Durchmesser Schauglas / sight glass diameter

# SGL Edelstahl / stainless steel

Schauglas  
Inspection glass

für natürliche Gase und Flüssigkeiten (z.B. NH<sub>3</sub>, CO<sub>2</sub>) und nicht korrosive Medien nach EN 378-1  
for natural gases and liquids (e.g. NH<sub>3</sub>, CO<sub>2</sub>) as well as non-corrosive media according to EN 378-1

## SGL SE NIRO HT

SE - Schraubenden / screwed ends

HT – Temperatur bis +200°C / temperature until +200°C

Druck- / Temperatureinsatzgrenzen:

Pressure - / temperature limits of application:

PS: max. zulässiger Betriebsdruck in bar ü / max. allowable working pressure in bar gauge

TS: den zulässigen Betriebsüberdrücken (PS) zugeordnete zulässige Betriebstemperatur in °C / max. allowable working temperature in °C, associated with PS

DN / INCH	PN	-50	-10	+50	+120	TS [°C]
DN 6...20 1/8" ...3/4"	PN25	25	25	25	25	PS [bar]
	PN40	40	40	40	40	PS [bar]
	PN63	63	63	63	63	PS [bar]

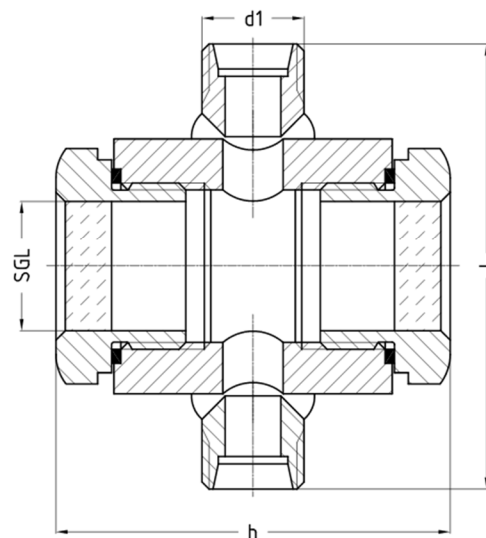

Abmessungen / dimensions in mm:

Nominal size:	Schraubenden gemäß: screwed ends acc. to:	l	h	Ø SGL*
DN	d1*			
6	G3/8"	96	85	28
8	G1/2"	105	85	28
8	G1/4"-i	105	85	28
8	M16x1,5 L RA10	96	85	28
8	M18x1,5 S RA10	96	85	28
8	M18x1,5 L RA 12	96	85	28
10	M26x1,5	96	85	28
15	G1"	126	85	28
20	M36x2,0 L RA28	126	85	28
20	G1 1/4"	126	85	28

d1\* = andere Gewindeanschlüsse siehe technischer Anhang / other thread connections see technical appendix

Ø SGL\* = Durchmesser Schauglas / sight glass diameter

# DA Werkstoffe / materials

Benennung und Materialien / naming and materials

DA HAT - Durchflussanzeiger / flow indicators

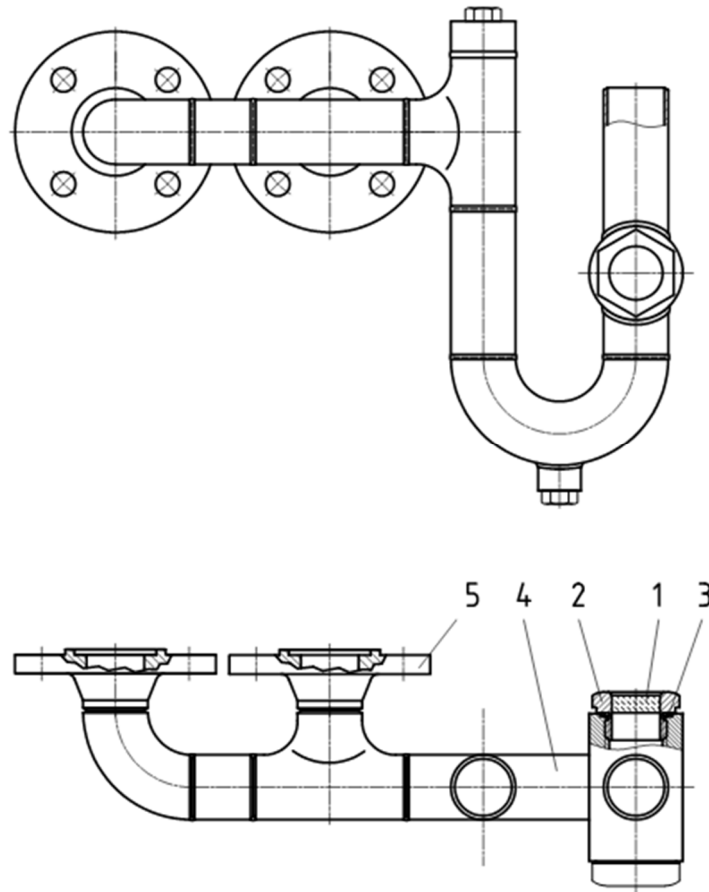

	Einzelteil / part:	Werkstoff Stahlventile material steel valves	Werkstoff Edelstahlventile material stainless steel valves
1	Glas / glass	Kalknatronglas / soda-lime glass	Kalknatronglas / soda-lime glass
2	Schraubstück / threaded nipple	S235JR 1.0038	X5CrNi18-10 1.4301
3	Flachdichtung / flat gasket	AL	AL
4	Gehäuse / body	S355J2 1.0577 P235GH 1.0345	X5CrNi18-10 1.4301
5	Flansch / flange	P250GH 1.0460	X6CrNiTi18-10 1.4541



# DA Stahl / steel

## Durchflussanzeiger Flow indicators

für natürliche Gase und Flüssigkeiten (z.B. NH<sub>3</sub>, CO<sub>2</sub>) und nicht korrosive Medien nach EN 378-1  
for natural gases and liquids (e.g. NH<sub>3</sub>, CO<sub>2</sub>) as well as non-corrosive media according to EN 378-1

### DA FL HT

**FL** - Flanschenden / flanged ends

**HT** – Temperatur bis +200°C / temperature until +200°C

Anwendung / application:

Durchflussanzeiger für Wechsel-Sicherheitsventil-Kombination

Druck- / Temperatureinsatzgrenzen:

Pressure- / temperature limits of application:

**PS:** max. zulässiger Betriebsdruck in bar ü / max. allowable working pressure in bar gauge

**TS:** den zulässigen Betriebsüberdrücken (PS) zugeordnete zulässige Betriebstemperatur in °C / max. allowable working temperature in °C, associated with PS

DN / INCH	PN	-10	+50	+200	TS [°C]
<b>DN 20...100</b> <b>3/4" ...4"</b>	PN25	25	25	25	PS [bar]
	PN40	40	40	40	PS [bar]
	PN63	63	63	63	PS [bar]

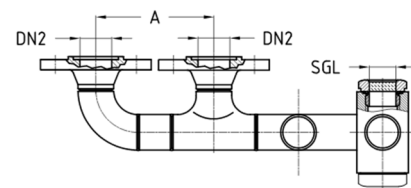
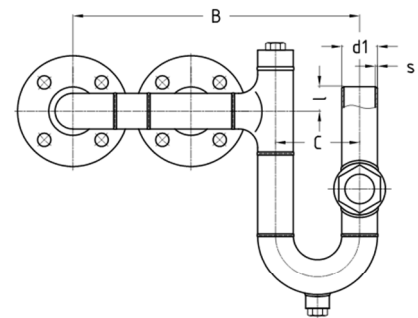

Abmessungen / dimensions in mm:

Nominal size: Eintritt / inlet: DA FL		Anschweißenden gemäß: / butt welding ends acc. to: <b>ISO Reihe 1</b> <b>ISO series 1</b>							
DN2*	WVR-DN DN1*	d1	s <sup>1)</sup>	s <sup>2)</sup>	l	A <sup>1)</sup>	B <sup>1)</sup>	C	Ø SGL*
20	10	26,9	2,3	2,6	45	108,0	224	58	28
25	15	33,7	2,6	2,6	33	120,0	272	76	28
32	20	42,4	2,6	2,9	33	150,0	343	96	28
40	25	48,3	2,6	2,9	33	160,0	389	114	40
50	32	60,3	2,9	2,9	86	180,0	461	152	40
65	40	76,1	2,9	3,2	97	214,0	556	190	40
80	50	88,9	3,2	3,6	123	228,0	629	228	40
100	65	114,3	3,6	4,0	144	276,0	791	304	40

DN1\* = passend für Wechsel-Sicherheitsventil-Kombination mit Wechselventil DN1

DN2\* = Ausgang Sicherheitsventile /outlet safety valves

Ø SGL = Durchmesser Schauglas / sight glass diameter

1) PN25 / PN40 2) PN63

DIN/EN-Flanschdichtflächen serienmäßig Feder DIN2512 / DIN/EN-flange facing standard tongue DIN2512

# Anhang / appendix

## Vergleich europäische / amerikanische Werkstoffe Comparison American vs. European material numbers

GEA AWP - Ventile enthalten Einzelteile in unterschiedlichen Werkstoffen. Die folgende Tabelle enthält alle Werkstoffe, die GEA AWP für drucktragende Teile verwendet und listet die amerikanischen Vergleichswerkstoffe auf.

GEA AWP valves contain several components made from different materials. The following table includes all European and corresponding American material numbers, which are used for the pressure related valve parts.

Europäischer Werkstoff European material numbers			Amerikanischer Vergleichswerkstoff Corresponding American material numbers	
Werkstoffnummer material number	Kurzname steel name	Norm standard	Werkstoffnorm material standard	Sorte grade
<b>Armaturen aus C-Stahl / steel valves</b>				
1.0345	P235GH, TC1 +N	DIN EN 10216-2	ASTM A106	A + B
1.0038	S235JR +N	DIN EN 10025-2	ASTM A570	36
1.0425	P265GH	DIN EN 10028-2	ASTM A516	60
1.0577	S355J2 +N	DIN EN 10025-2	ASTM A516	65
1.6220	G20Mn5 +QT	DIN EN 10213	ASTM A352	LCC
1.0460	C22.8	VdTÜV 350/3	ASTM A105	-
<b>Armaturen aus TT-Stahl / low temp steel valves</b>				
1.0451	P215NL +N	DIN EN 10216-4	ASTM A333	6
1.0452	P255QL +QT	DIN EN 10216-4		
1.0566	P355NL1 +N	DIN EN 10028-3 DIN 17103 VdTÜV 354/3	ASTM A662 ASTM A420 ASTM A350	B WPL6 LF2
1.0488	TStE 285	DIN 17103 VdTÜV 352/3	ASTM A662 ASTM A350	A LF2
1.6220	G20Mn5 +QT	DIN EN 10213	ASTM A352	LCC
<b>Armaturen aus Edelstahl / stainless steel valves</b>				
1.4301	X5CrNi18-10	DIN EN 10216-5 DIN EN 10028-7 DIN EN 10222-5	ASTM A312 ASTM A240	TP304 304
1.4581	GX5CrNiMoNb19-11-2	DIN EN 1092-1 DIN EN 10213	ASTM A182 ASTM A351	F304 CF10M

Durchgangsventile in nicht standardmäßiger Ausführung (z.B. abweichende Werkstoffe, Abnahme durch Dritte) sind nur in Schrägsitzform lieferbar.

Straightway valves of not standard design (e.g. deviant materials, inspection by third parties) are available only in y-type form.

# Anhang / appendix

## Codierung Anschlüsse Klein- und Serviceventile Connection codes for service valves and small valves

GEA AWP - Ventile können mit einer Vielzahl von Anschlussvarianten hergestellt werden:  
GEA AWP valves are produced with a wide range of different connections:

DN	Gewinde / Thread	Code	Anschweißenden / Welding ends	Abmessung / Dimensions	Code
DN8	M12x1,5 RA6	AL	DN6 R1	Ø10,2x1,6	C0
DN8	M12x1,5-keg	AY	ANSI 40	Ø1/8"x1,7	C1
DN8	M14x1,5 RA8	A4	ANSI 80	Ø1/8"x2,4	C2
DN8	M16x1,5 RA8	A5			
DN8	M16x1,5 RA10	A6	DN8 R1	Ø13,5x1,8	D0
DN8	M16x1,5-i	AZ	ANSI 40	Ø1/4"x2,2	D1
DN8	M16x1,5-keg	AC	ANSI 80	Ø1/4"x3,0	D2
DN8	M18x1,5 RA10	A7	12x2	Ø12x2,0	D3
DN8	M18x1,5 RA12	A8	12x3	Ø12x3,0	D4
DN8	M20x1,5 RA12	A9	R1 Verl. L2=130 Niro	Ø13,5x1,8	D5
DN8	M22x1,5 RA14	AA	R1 Verl. L2=130 C-St.	Ø13,5x1,8	D6
DN8	M22x1,5 RA15	AB			
DN8	M22x1,5	A0	DN10 R1	Ø17,2x1,8	E0
DN8	M22x1,5-keg	AD	ANSI 40	Ø3/8"x2,3	E1
DN20	M26x1,5 RA18	AS	ANSI 80	Ø3/8"x3,2	E2
DN20	M30x2 RA22	AT	R2	Ø15x2,5	E3
DN8	G1/4"	AF	18x3	Ø18x3,0	E4
DN8	G1/4"-keg	AG	R1 Verl. L2=130 Niro	Ø17,2x1,8	E5
DN8	G1/4"-i	AH	R1 Verl. L2=130 C-St.	Ø17,2x1,8	E6
DN8	G3/8"	AK	16x4 Verl.L2=130Niro	Ø16x4,0	E7
DN8	G3/8"-i	AM	17,2x2	Ø17,2x2,0	E8
DN8	G3/8" RA10	AJ	R1 Verl. L2=120 C-St.	Ø17,2x1,8	E9
DN8	G1/2"	A1	R1 Verl. L2=140 Niro	Ø17,2x1,8	EA
DN8	G1/2"-lks	A2	R1 Verl. L2=140 C-St.	Ø17,2x1,8	EB
DN8	G1/2" RA12	AN	R1 Verl. L2=60 Niro	Ø17,2x1,8	EC
DN8	G1/2"-i	AU	R1 Verl. L2=60 C-St.	Ø17,2x1,8	ED
DN8	G1/2" UM *)	AV	18x4 Verl.L2=140 Niro	Ø18x4,0	EE
DN8	G1/2" **)	AW	18x4 Verl.L2=140C-St	Ø18x4,0	EF
DN8	G1/2"-keg	AX	18x4 Verl.L2=60 Niro	Ø18x4,0	EG
DN20	G3/4"	AE	18x4 Verl.L2=60 C-St.	Ø18x4,0	EH
DN20	G3/4" RA18	AP			
DN8	1/4"NPT-male	A3	DN15 R1	Ø21,3x2,0	F0
DN8	1/4"NPT-female	AR	ANSI 40	Ø1/2"x2,8	F1
DN8	3/8"NPT-male	AI	ANSI 80	Ø1/2"x3,7	F2
DN8	3/8"NPT-female	B2	R2	Ø20x2,5	F3
DN8	1/2"NPT-male	B0	R1 Verl. L2=130 Niro	Ø21,3x2,0	F5
DN8	1/2"NPT-female	B1	R1 Verl. L2=130 C-St.	Ø21,3x2,0	F6
DN20	3/4"NPT-male	B3	R1 Verl. L2=180 NIRO	Ø21,3x2,0	F7
DN8	M10-a	B4	ANSI 80 L2=130 C-St	Ø21,3x3,7	F8
DN20	G1"	B6			
DN8	G3/8" BSPT-male	B7			
DN8	G3/8" BSPT-female	B8			
DN8	3/8-18 NPTF-male	B9			
DN8	R3/8"-keg	BA			

\*) drehbar mit Gehäuse verschweißt / swiveling with body welds together  
\*\*) für einteilige Blindmutter / for one-piece blind nut

i = Innengewinde / internal thread / a = Außengewinde / outside thread

Diese Anschlüsse können mit Zubehör ausgerüstet werden. / These connections might be equipped with fittings.

	Zubehör	fittings	Kurzbez. / shortcut	Code
UM+ST	Überwurfmutter mit Schweißstülle	cap nut with tail	UM+ST	1
BM	Blindmutter	blind nut	BM	2
DM	Doppelmutter links/rechts	double nut left/right	DM	3
UM+SKB	Überwurfmutter mit Schweißkugelbuchse	cap nut with weld ball type nipple	UM+SKB	4
UM+SR	Überwurfmutter mit Schneidring	cap nut with cutting ring	UM+SR	5
UM+SLT	Überwurfmutter mit Schlauchtülle	cap nut with hose nipple	UM+SLT	6
DM+Adapter	Doppelmutter mit Adapter G1/2"-a/G1/4"-i	double nut left/right with adaptor G1/2"-a/G1/4"-i	DM+Adapter	7
UM+KKR	Überwurfmutter mit Klemmkeilring	cap nut with wedge ring	UM+KKR	9

# DIN-FL

## Vorschweißflansche - DIN 2634/2635 Welding neck flanges - DIN 2634/2635

DIN-FL N

DIN-FL F

DIN-FL C

DIN-FL D

FL - Flansch / flange

Form N - Nut / groove, DIN 2512

Form F - Feder / tongue, DIN 2512

Form C - glatte Dichtleiste / raised face, (Rz160) DIN2526

Form D - glatte Dichtleiste / raised face, (Rz 40) DIN2526

DN 10-150 DIN 2635 PN 4,0,  
DN 200 DIN 2634 PN 2,5

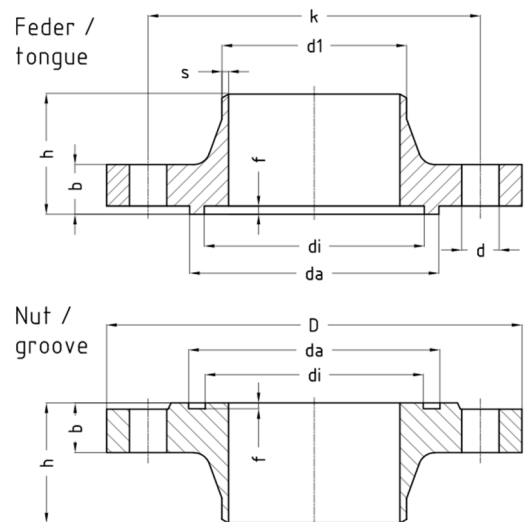

Einbaulängen / lengths in mm:

DIN2634 PN25 DN10-150 / DIN 2635 PN40 DN10-400																				
DN	Anschweißenden / butt welding ends				Dichtleistenausführung / types of contact face								Schrauben / screws DIN 931			Dichtring / sealing DIN 2691				
	Reihe 1 series 1		Reihe 2 series 2		Nut / groove				Feder / tongue				Anzahl quantity	Gewinde thread	Länge length	di	da			
	d1	s	d1	s	b	k	h	d	D	di	da	f	di	da	f				di	da
10	17,2	1,8	15,0	2,5	16	60	35	14	90	23	35	2,5	24	34	4,0	4	M 12	45	24	34
15	21,3	2,0	20,0	2,5	16	65	38	14	95	28	40	2,5	29	39	4,0	4	M 12	45	29	39
20	26,9	2,3	25,0	2,5	18	75	40	14	105	35	51	2,5	36	50	4,0	4	M 12	50	36	50
25	33,7	2,6	32,0	3,0	18	85	40	14	115	42	58	2,5	43	57	4,0	4	M 12	50	43	57
32	42,4	2,6	38,0	3,0	18	100	42	18	140	50	66	2,5	51	65	4,0	4	M 16	55	51	65
40	48,3	2,6	45,0	3,0	18	110	45	18	150	60	76	2,5	61	75	4,0	4	M 16	55	61	75
50	60,3	2,9	57,0	3,2	20	125	48	18	165	72	88	2,5	73	87	4,0	4	M 16	60	73	87
65	76,1	2,9	76,1	3,6	22	145	52	18	185	94	110	2,5	95	109	4,0	8	M 16	60	95	109
80	88,9	3,2	88,9	4,0	24	160	58	18	200	105	121	2,5	106	120	4,0	8	M 16	65	106	120
100	114,3	3,6	108,0	4,0	24	190	65	22	235	128	150	3,0	129	149	4,5	8	M 20	70	129	149
125	139,7	4,0	133,0	4,0	26	220	68	26	270	154	176	3,0	155	175	4,5	8	M 24	80	155	175
150	168,3	4,5	159,0	4,5	28	250	75	26	300	182	204	3,0	183	203	4,5	8	M 24	80	183	203
200	219,1	6,3			34	320	88	30	375	238	260	3,0	239	259	4,5	12	M 27	100	239	259
250	273,0	7,1			38	385	105	33	450	291	313	3,0	292	312	4,5	12	M 30	110	292	312
300	323,9	8,0			42	450	115	33	515	342	364	3,0	343	363	4,5	16	M 30	120	343	363
350	355,6	8,8			46	510	125	36	580	394	422	3,5	395	421	5,0	16	M 33	130	395	421
400	406,4	11,0			50	585	135	39	660	446	474	3,5	447	473	5,0	16	M 36	140	447	473

# DIN-FL

## Vorschweißflansche - DIN 2634/2636/2637 Welding neck flanges - DIN 2634/2636/2637

DIN-FL N

DIN-FL F

DIN-FL C

DIN-FL D

FL - Flansch / flange

Form N - Nut / groove, DIN 2512

Form F - Feder / tongue, DIN 2512

Form C - glatte Dichtleiste / raised face, (Rz160) DIN2526

Form D - glatte Dichtleiste / raised face, (Rz40) DIN2526

DN 10-150 DIN 2635 PN 4,0,  
DN 200 DIN 2634 PN 25

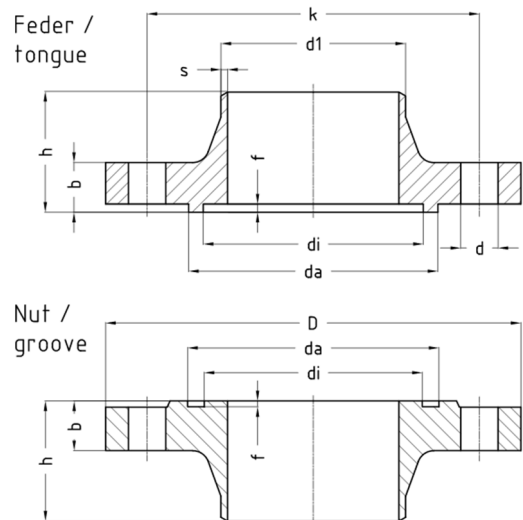

Einbaulängen / lengths in mm:

DIN 2634 PN25 DN200-500																		
DN	Anschweißenden / butt welding ends Reihe 1 series 1		Dichtleistenausführung / types of contact face					Schrauben / screws DIN 931			Dichtring / sealing ring DIN 2691							
	d1	s	Nut / groove		Feder / tongue			Anzahl quantity	Gewinde thread	Länge length	di	da						
	b	k	h	d	D	di	da	f	di	da	f							
200	219,1	6,3	30	310	80	26	360	238	260	3,0	239	259	4,5	12	M 24	90	239	259
250	273,0	7,1	32	370	88	30	425	291	313	3,0	292	312	4,5	12	M 27	90	292	312
300	323,9	8,0	34	430	92	30	485	342	364	3,0	343	363	4,5	16	M 27	100	343	363
350	355,6	8,0	38	490	100	33	555	394	422	3,5	395	421	5,0	16	M 30	110	395	421
400	406,4	8,8	40	550	110	36	620	446	474	3,5	447	473	5,0	16	M 33	120	447	473
500	508,0	10,0	44	660	125	36	730	548	576	3,5	549	575	5,0	20	M 33	130	549	575

DIN2636 PN63 DN10-40 / DIN 2637 PN100 DN10-40																		
DN	d1	s	b	k	h	d	D	di	da	f	di	da	f	Anzahl quantity	Gewinde thread	Länge length	di	Da
10	17,2	2,0	20	70	45	14	100	23	35	2,5	24	34	4,0	4	M 12	55	24	34
15	21,3	2,0	20	75	45	14	105	28	40	2,5	29	39	4,0	4	M 12	55	29	39
20	26,9	2,6	22	90	48	18	130	35	51	2,5	36	50	4,0	4	M 16	60	36	50
25	33,7	2,6	24	100	58	18	140	42	58	2,5	43	57	4,0	4	M 16	65	43	57
32	42,4	2,9	24	110	60	22	155	50	66	2,5	51	65	4,0	4	M 20	70	51	65
40	48,3	2,9	26	125	62	22	170	60	76	2,5	61	75	4,0	4	M 20	70	61	75

DIN 2636 PN63 DN50-125																		
DN	d1	S	b	k	h	d	D	di	da	f	di	da	f	Anzahl quantity	Gewinde thread	Länge length	di	da
50	60,3	2,9	26	135	62	22	180	72	88	2,5	73	87	4,0	4	M 20	75	73	87
65	76,1	3,2	26	160	68	22	205	94	110	2,5	95	109	4,0	8	M 20	75	95	109
80	88,9	3,6	28	170	72	22	215	105	121	2,5	106	120	4,0	8	M 20	75	106	120
100	114,3	4,0	30	200	78	26	250	128	150	3,0	129	149	4,5	8	M 24	90	129	149
125	139,7	4,5	34	240	88	30	295	154	176	3,0	155	175	4,5	8	M 27	100	155	175

# DIN EN-FL

Vorschweißflansche - DIN EN 1092-1  
Welding neck flanges - DIN EN 1092-1

**DIN EN-FL D**

**DIN EN-FL C**

**DIN EN-FL B1**

**DIN EN-FL B2**

FL - Flansch / flange

**Form D** - Nut / groove, DIN EN 1092-1

**Form C** - Feder / tongue, DIN EN 1092-1

**Form B1** - glatte Dichtleiste / raised face (Rz50) DIN EN 1092-1

**Form B2** - glatte Dichtleiste / raised face (Rz12,5) DIN EN 1092-1

DN 10-150 DIN 2635 PN 4,0,  
DN 200 DIN 2634 PN 25

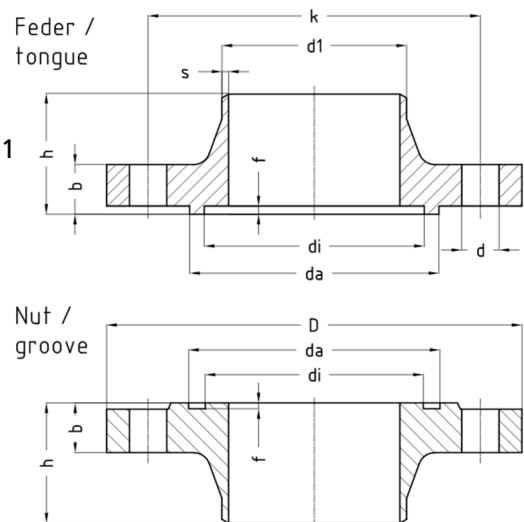

Einbaulängen / lengths in mm:

DIN EN 1092-1 PN25 DN10-150 / PN40 DN10-400																				
DN	Anschweißenden / butt welding ends				Dichtleistenausführung / types of contact face								Schrauben / screws DIN 931			Dichtring / sealing ring DIN 2691				
	Reihe 1 series 1		Reihe 2 series 2		Nut / groove				Feder / tongue				Anzahl quantity	Gewinde thread	Länge length	di	da			
	d1	s	d1	s	b	k	h	d	D	di	da	f	di	da	f					
10	17,2	1,8	15,0	2,5	16	60	35	14	90	23	35	4,0	24	34	4,5	4	M 12	45	24	34
15	21,3	2,0	20,0	2,5	16	65	38	14	95	28	40	4,0	29	39	4,5	4	M 12	45	29	39
20	26,9	2,3	25,0	2,5	18	75	40	14	105	35	51	4,0	36	50	4,5	4	M 12	50	36	50
25	33,7	2,6	32,0	3,0	18	85	40	14	115	42	58	4,0	43	57	4,5	4	M 12	50	43	57
32	42,4	2,6	38,0	3,0	18	100	42	18	140	50	66	4,0	51	65	4,5	4	M 16	55	51	65
40	48,3	2,6	45,0	3,0	18	110	45	18	150	60	76	4,0	61	75	4,5	4	M 16	55	61	75
50	60,3	2,9	57,0	3,2	20	125	48	18	165	72	88	4,0	73	87	4,5	4	M 16	60	73	87
65	76,1	2,9	76,1	3,6	22	145	52	18	185	94	110	4,0	95	109	4,5	8	M 16	60	95	109
80	88,9	3,2	88,9	4,0	24	160	58	18	200	105	121	4,0	106	120	4,5	8	M 16	65	106	120
100	114,3	3,6	108,0	4,0	24	190	65	22	235	128	150	4,5	129	149	5,0	8	M 20	70	129	149
125	139,7	4,0	133,0	4,0	26	220	68	26	270	154	176	4,5	155	175	5,0	8	M 24	80	155	175
150	168,3	4,5	159,0	4,5	28	250	75	26	300	182	204	4,5	183	203	5,0	8	M 24	80	183	203
200	219,1	6,3			34	320	88	30	375	238	260	4,5	239	259	5,0	12	M 27	100	239	259
250	273,0	7,1			38	385	105	33	450	291	313	4,5	292	312	5,0	12	M 30	110	292	312
300	323,9	8,0			42	450	115	33	515	342	364	4,5	343	363	5,0	16	M 30	120	343	363
350	355,6	8,8			46	510	125	36	580	394	422	5,0	395	421	5,5	16	M 33	130	395	421
400	406,4	11,0			50	585	135	39	660	446	474	5,0	447	473	5,5	16	M 36	140	447	473

# DIN EN-FL

Vorschweißflansche - DIN EN 1092-1  
Welding neck flanges - DIN EN 1092-1

DIN EN-FL D

DIN EN-FL C

DIN EN-FL B1

DIN EN-FL B2

FL - Flansch / flange

Form D - Nut / groove, DIN EN 1092-1

Form C - Feder / tongue, DIN EN 1092-1

Form B1 - glatte Dichtleiste / raised face, (Rz50) DIN EN 1092-1

Form B2 - glatte Dichtleiste / raised face, (Rz12,5) DIN EN 1092-1

DN 10-150 DIN 2635 PN 4,0,  
DN 200 DIN 2634 PN 25

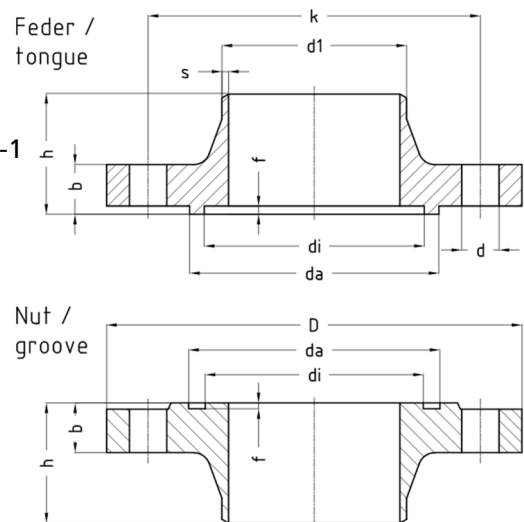

Einbaulängen / lengths in mm:

DIN EN 1092-1 PN25 DN200-500																		
DN	Anschweißenden / butt welding ends Reihe 1 series 1		Dichtleistenausführung / types of contact face					Schrauben / screws DIN 931			Dichtring / sealring DIN 2691							
	d1	s	Nut / groove		Feder / tongue			Anzahl quantity	Gewinde thread	Länge length	di	da						
	b	k	h	d	D	di	da	f	di	da	f							
200	219,1	6,3	30	310	80	26	360	238	260	4,5	239	259	5,0	12	M 24	90	239	259
250	273,0	7,1	32	370	88	30	425	291	313	4,5	292	312	5,0	12	M 27	90	292	312
300	323,9	8,0	34	430	92	30	485	342	364	4,5	343	363	5,0	16	M 27	100	343	363
350	355,6	8,0	38	490	100	33	555	394	422	5,0	395	421	5,5	16	M 30	110	395	421
400	406,4	8,8	40	550	110	36	620	446	474	5,0	447	473	5,5	16	M 33	120	447	473
500	508,0	10,0	44	660	125	36	730	548	576	5,0	549	575	5,5	20	M 33	130	549	575
DIN EN 1092-1 PN63 DN10-40 / PN100 DN10-40																		
DN	d1	s	b	k	h	d	D	di	da	F	di	da	f	Anzahl quantity	Gewinde thread	Länge length	di	Da
10	17,2	2,0	20	70	45	14	100	23	35	4,0	24	34	4,5	4	M 12	55	24	34
15	21,3	2,0	20	75	45	14	105	28	40	4,0	29	39	4,5	4	M 12	55	29	39
20	26,9	2,6	22	90	48	18	130	35	51	4,0	36	50	4,5	4	M 16	60	36	50
25	33,7	2,6	24	100	58	18	140	42	58	4,0	43	57	4,5	4	M 16	65	43	57
32	42,4	2,9	24	110	60	22	155	50	66	4,0	51	65	4,5	4	M 20	70	51	65
40	48,3	2,9	26	125	62	22	170	60	76	4,0	61	75	4,5	4	M 20	70	61	75
DIN EN 1092-1 PN63 DN50-125																		
DN	d1	S	b	k	h	d	D	di	da	f	di	da	F	Anzahl quantity	Gewinde thread	Länge length	di	da
50	60,3	2,9	26	135	62	22	180	72	88	4,0	73	87	4,5	4	M 20	75	73	87
65	76,1	3,2	26	160	68	22	205	94	110	4,0	95	109	4,5	8	M 20	75	95	109
80	88,9	3,6	28	170	72	22	215	105	121	4,0	106	120	4,5	8	M 20	75	106	120
100	114,3	4,0	30	200	78	26	250	128	150	4,5	129	149	5,0	8	M 24	90	129	149
125	139,7	4,5	34	240	88	30	295	154	176	4,5	155	175	5,0	8	M 27	100	155	175

# ANSI-FL

Vorschweißflansche - ANSI B 16.5 glatte Dichtleiste  
 Welding neck flanges - ANSI B 16.5 raised face

**ANSI-FL 150lbs RF**

**ANSI-FL 300lbs RF**

FL - Flansch / flange

Flächenbearbeitung mit großem und kleinem Vorsprung / Rücksprung /  
 Flächenbearbeitung mit großer und kleiner Feder / Nut nach ANSI B 16.5  
 Large and small male / female facings /  
 Large and small tongue / groove facings 150-2500lbs / sq. in see ANSI B 16.5

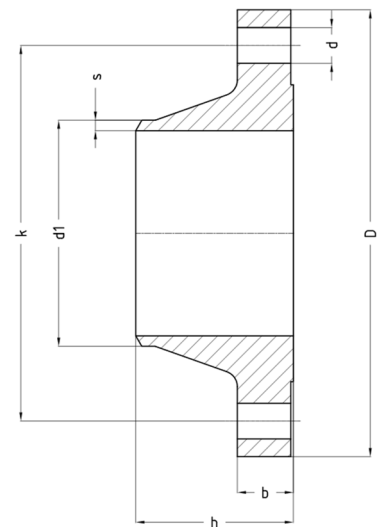

Einbaulängen / lengths in mm :

Nominale size		Anschweißenden gemäß: / butt welding ends acc. to:													
		ANSI		ANSI-FL 150lbs RF / sq. in				Schrauben / screws DIN 931		ANSI-FL 300lbs RF / sq. in				Schrauben / screws DIN 931	
DN	INCH	d1	s	b	k	h	d	D	Anzahl quantity	b	k	h	d	D	Anzahl quantity
15	1/2"	21,3	2,8	11,2	60,5	47,8	15,7	88,9	4	14,2	66,5	52,3	15,7	95,2	4
20	3/4"	26,7	2,9	12,7	69,9	52,3	15,7	98,6	4	15,7	82,5	57,1	19,0	117,3	4
25	1"	33,4	3,4	14,2	79,2	55,6	15,7	108,0	4	17,5	88,9	62,0	19,0	123,9	4
32	1 1/4"	42,2	3,6	15,7	88,9	57,2	15,7	117,3	4	19,0	98,5	65,0	19,0	133,3	4
40	1 1/2"	48,3	3,7	17,5	98,6	62,0	15,7	127,0	4	20,6	114,3	68,3	22,3	155,4	4
50	2"	60,3	3,9	19,1	120,7	63,5	19,1	152,4	4	22,3	127,0	69,8	19,0	165,1	6
65	2 1/2"	73,0	5,2	22,4	139,7	69,9	19,1	177,8	4	25,4	149,3	76,2	22,3	190,5	8
80	3"	88,9	5,5	23,9	152,4	69,9	19,1	190,5	4	28,4	168,1	79,2	22,3	209,5	8
100	4"	114,3	6,0	23,9	190,5	76,2	19,1	228,6	8	31,7	200,1	85,8	22,3	254,0	8
125	5"	141,3	6,6	23,9	215,9	88,9	22,4	254,0	8	35,0	234,9	98,5	22,3	279,4	8
150	6"	168,3	7,1	25,4	241,3	88,9	22,4	279,4	8	36,5	269,7	98,5	22,3	317,5	12
200	8"	219,1	8,2	28,4	298,5	101,6	22,4	342,9	8	41,1	330,2	111,2	25,4	381,0	12
250	10"	273,0	9,3	30,2	362,0	101,6	25,4	406,4	12	47,7	387,3	117,3	28,4	444,5	16
300	12"	323,8	10,3	31,8	431,8	114,3	25,4	482,6	12	50,8	450,8	130,0	31,7	520,7	16
350	14"	355,6	11,1	35,1	476,3	127,0	28,4	533,4	12	53,8	514,3	142,7	31,7	584,2	20
400	16"	406,4	12,7	36,6	539,8	127,0	28,4	596,9	16	57,1	571,5	146,0	35,0	647,7	20



# AWP-FL

Vorschweißflansche - AWP  
Welding neck flanges - AWP

**AWP-FL N**  
**AWP-FL F**  
FL - Flansch / flange  
N - Nut / groove  
F - Feder / tongue

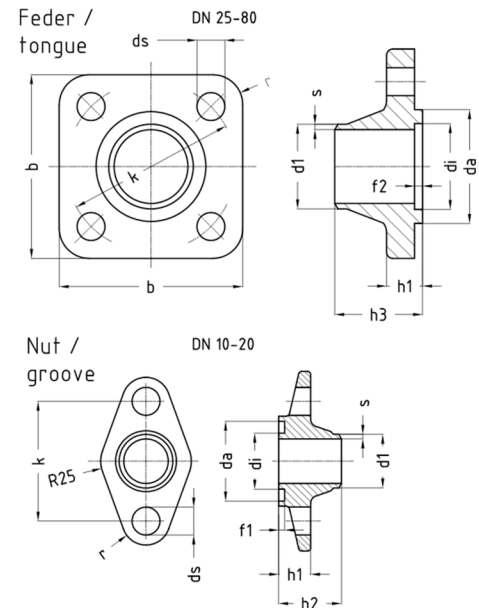

Einbaulängen / lengths in mm:

AWP-FL PN25 DN10-20 / PN40 DN25-80																								
DN	Anschweißenden / butt welding ends						Dichtleistenausführung / types of contact face								Schrauben / screws DIN 931			Dichtring / sealring DIN 2691						
	Reihe 1 / series 1		Reihe 2 / series 2		ANSI										Anzahl / quantity	Gewinde / thread	Länge / length	di	da					
	d1	s	d1	s	d1	s	b	k	r	h1	ds	Nut / groove								Feder / tongue				
											di	da	f1	h2	di	da	f2	h3						
10	17,2	1,8	15,0	2,5	17,1	2,3	88	60	13	16	14	28	40	3	31,5	29	39	4	32,0	2	M 12	45	29	39
15	21,3	2,0	20,0	2,5	21,3	2,8	88	60	13	16	14	28	40	3	31,5	29	39	4	32,0	2	M 12	45	29	39
20	26,9	2,3	25,0	2,5	26,7	2,9	88	60	13	16	14	28	40	3	31,5	29	39	4	32,0	2	M 12	45	29	39
25	33,7	2,6	32,0	3,0	33,4	3,4	92	85	15	18	14	42	58	3	44,0	43	57	4	44,0	4	M 12	50	43	57
32	42,4	2,6	38,0	3,0	42,2	3,6	92	85	15	18	14	42	58	3	44,0	43	57	4	44,0	4	M 12	50	43	57
40	48,3	2,6	45,0	3,0	48,3	3,7	92	85	15	18	14	42	58	3	38,5	43	57	4	38,5	4	M 12	50	43	57
50	60,3	2,9	57,0	3,2	60,3	3,9	132	135	20	28	18	84	96	3	43,0	85	95	4	43,0	4	M 16	75	A85x95*	
65	76,1	2,9	76,1	3,6	73,0	5,2	132	135	20	28	18	84	96	3	53,5	85	95	4	53,5	4	M 16	75	A85x95*	
80	88,9	3,2	88,9	4,0	88,9	5,5	132	135	20	28	18	84	96	3	53,5	85	95	4	53,5	4	M 16	75	A85x95*	

\* = nach DIN 7603 / acc. to DIN 7603

# Anhang / appendix

## Rechtlicher Hinweis Legal Note

### Rechtlicher Hinweis

GEA AWP Armaturen sind gemäß den GEA AWP Betriebsvorschriften zu handhaben.  
Die in den Betriebsvorschriften genannten Sicherheitshinweise sind zu beachten.  
Es liegt eine Gefahrenanalyse für GEA AWP Armaturen vor.

Die Handhabung der GEA AWP Armaturen hat ausschließlich durch autorisierte Personen zu erfolgen.  
Dabei sind die Hinweise zum Gebrauch persönlicher Schutzausrüstung (PSA) zu beachten.  
Die GEA AWP Armaturen sind bestimmungsgemäß einzusetzen.

Dieser Katalog wurde sorgfältig erstellt und geprüft, kann aber dennoch Fehler enthalten. Die im Katalog gemachten technischen Angaben sind keine vertraglich zugesicherten Eigenschaften. Die technischen Angaben sind nur dann verbindlich, wenn Sie von uns schriftlich bestätigt wurden.

Wir behalten uns technische Änderungen vor.

Weitere Informationen zu unseren Konformitätserklärungen, Betriebsvorschriften, Berechnungsprogramm und den allgemeinen Geschäftsbedingungen finden Sie auf unserer Internetseite [www.awpvalves.com](http://www.awpvalves.com) im Register Tools/Downloads.

Es gelten unsere allgemeinen Geschäftsbedingungen.

### Legal Note

GEA AWP valves should be handled in accordance with the GEA AWP operating instructions.  
The safety notes mentioned inside the operating instructions have to be considered.  
A risk analysis for GEA AWP valves is available.

To handle GEA AWP valves is permitted for authorized personnel only.  
The advice to use personnel protective equipment (PPE) has to be considered.  
GEA AWP valves have to be used as intended.

This catalogue had been established carefully and had been reviewed in detail, nevertheless it might contain mistakes. The catalogue data is not contractually-guaranteed. The catalogue data is mandatory after confirmed in a written form by us.

Technical data are subject to change.

Other information to our declaration of conformity, operating instructions, calculation program and the standard business terms finds them on our Internet page [www.awpvalves.com](http://www.awpvalves.com) in the register Tools/Downloads.

Our standard business terms are valid.

